

Series LS8H

Hydraulic Cable Winches

Lift-Safe® hydraulic winches are specifically designed for lifting applications and optimum load control. Engineered for enhanced safety with redundant braking systems, and available in a variety of configurations. Lift-Safe® winches utilize the **DUET-SAFE® Double Action Braking System** to provide both static and dynamic braking. Lift-Safe® winches offer increased operational flexibility, and superior load control in lifting applications. The LS8H Series are direct drive for use in small cranes, rear load waste packers, drill rigs, fishing boats, marine craft, mining and logging operations.



**UP TO 8,000 LBS.
CAPACITY**

Lift-Safe® Hydraulic Cable Winches – Standard Features

- | | |
|--------------------|--|
| MOTOR-BRAKE | - DUET-SAFE® Double Action Braking System combines a powerful spring applied, hydraulic released motor-brake with a double counter balance brake valve to automatically hold loads when hydraulic pressure is released and control speed during lowering operations. Winch is ideal for high speed lifting and pulling applications or wherever load holding is critical. |
| GEAR CASE | - Made of high strength cast iron. Completely sealed for oil enclosed operation and to keep dirt out. |
| WORM SHAFT | - One piece alloy steel hardened and ground for extra durability. Compact design allows hydraulic motor to be coupled directly to worm. |
| WORM GEAR | - High tensile aluminum-nickel alloy bronze. Optimum lead and pressure angles transmit maximum power to the drum. |
| GEAR RATIO | - 20:1 standard, 10:1, optional ratios provide optimum efficiency in power and speed. |
| BEARINGS | - Worm gear and worm shaft run on tapered roller bearings. Outer end housing has sealed ball bearing. |
| DRUM SHAFT | - 1-1/4" diameter heat -treated alloy steel minimum tensile strength 150,000 psi. |
| CABLE DRUM | - Tough all steel construction resists breakage or warping. |



www.bloommfg.com

BLOOM

Manufacturing Inc.

Winch Division

"Custom Engineered Solutions"

**Lifting
Pulling
Hoisting**

Toll Free Number: 1-800-394-1139

1443 220th Street,, Independence, Iowa 50644 • FAX: 319-827-1140 • PHONE: 319-827-1139



"Quality Since 1910"

800H Series Model Selection from Performance Data

MODEL EXAMPLE: **LS8H-3.0T-L8-20-LP**

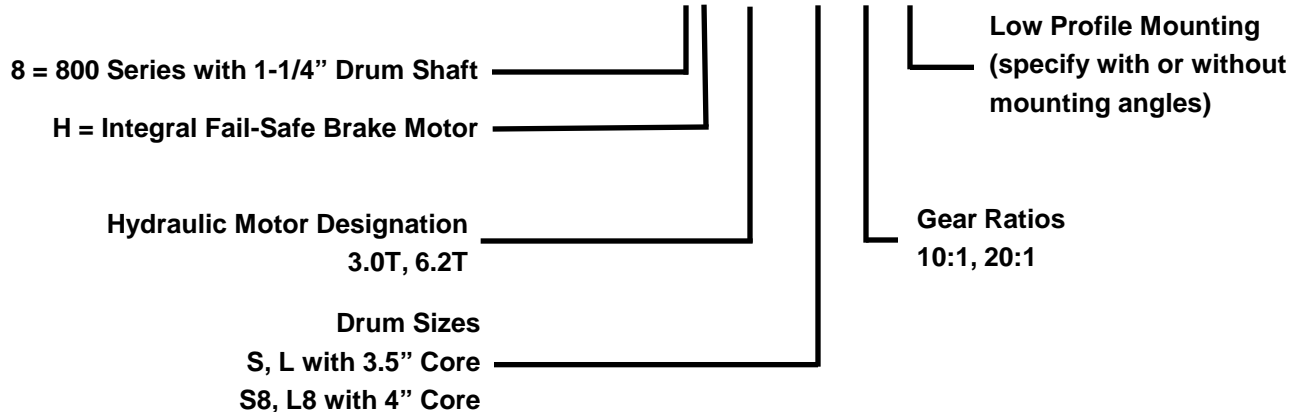

(LS8H) Indicates Lift-Safe® winch series 800H with 1-1/4" drum shaft.

(3.0T) Designates hydraulic motor. Motor size is determined from motor performance charts. All motors come with integral spring applied hydraulic release brake.

(L8) Select drum size from chart below:

DRUM CAPACITY

CABLE DIAMETER (IN.)	1/4	5/16	3/8	7/16	1/2
DRUM "S" CAPACITY (FT.)	120	70	45	30	25
DRUM "S8" CAPACITY (FT.)	260	160	105	75	55
DRUM "L" CAPACITY (FT.)	175	105	65	45	30
DRUM "L8" CAPACITY (FT.)	390	240	160	110	80

(20) Indicates gear ratio. 20:1 is standard. 10:1 is also available.

(LP) Design low profile mounting on 800H Series winches. 800H Low Profile Series winches with mounting angles are available with S, S8, L and L8 drums. However, it is necessary on all low profile whether the winch is to be supplied "with angles" or "less angles".

800H Series With Hydraulic Fail-Safe Brake Model Selection from Performance Data

10:1 RATIO (optional)

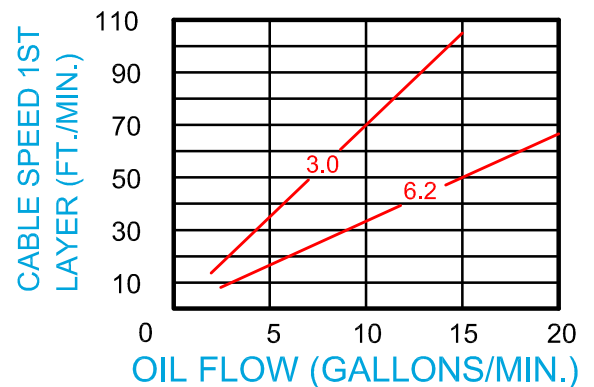
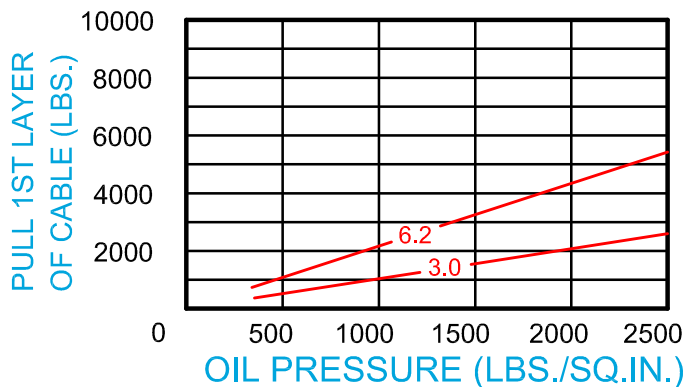

20:1 RATIO (standard)

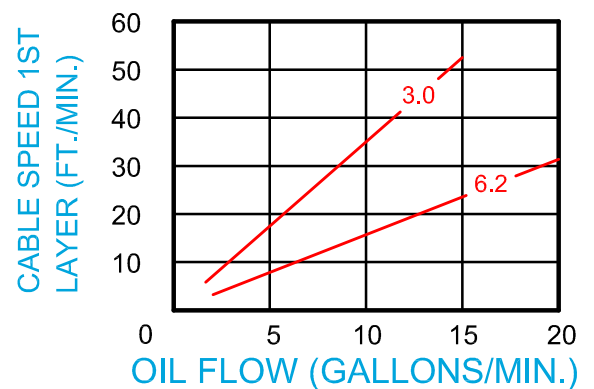
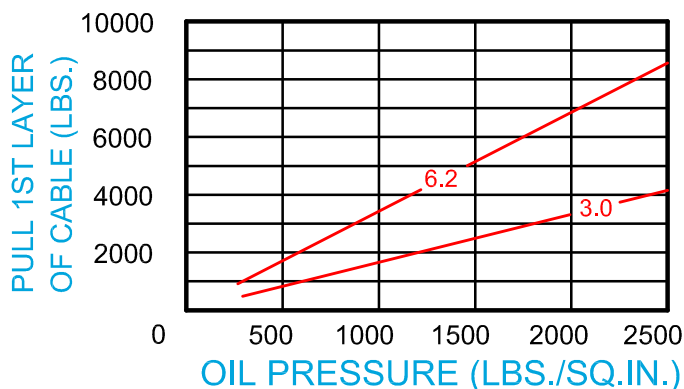

Bloom Manufacturing Inc.



LIFT-SAFE®

“Quality Since
1910”

Dimensional Drawings

800H Series With S, S8, L and L8 Drum
Base Mount Model - Direct Drive

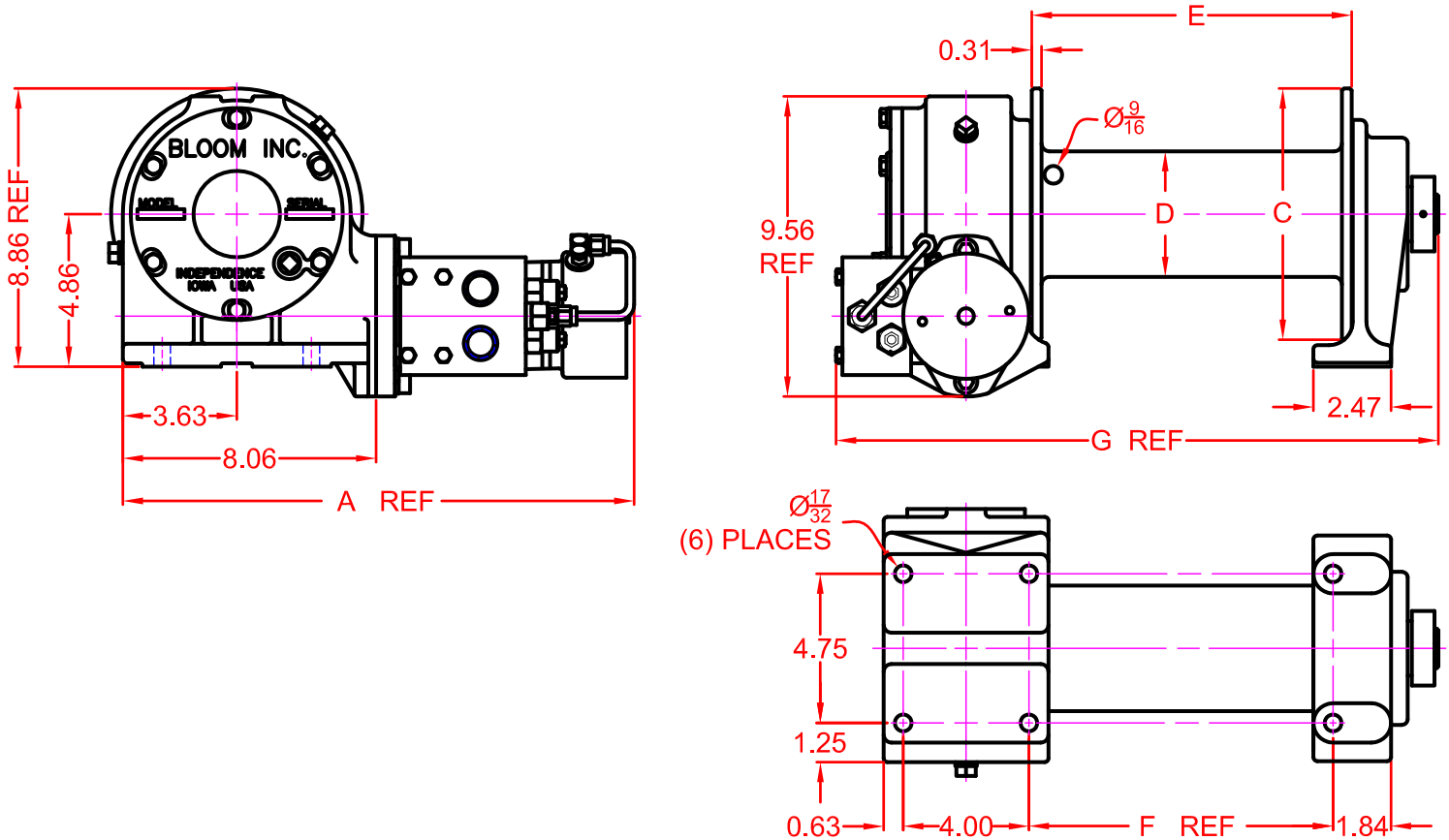

MOTOR DESIGNATION	3.0	6.2
A DIMENSION	15.91	16.28

DRUM DESIGNATION	WINCH DIMENSION				
	C	D	E	F	G
S	6	3.50	7.19	6.69	16.18
S8	8	4	7.19	6.69	16.18
L	6	3.50	10.19	9.69	19.18
L8	8	4	10.19	9.69	19.18

Bloom Manufacturing Inc.

Winch Division
1443 220th Street
Independence, IA 50644

www.bloommfg.com
Email: sales@bloommfg.com engineering@bloommfg.com

800-394-1139 tel
319-827-1139 tel
319-827-1140 fax



"Quality Since
1910"

LIFT-SAFE®

Dimensional Drawings

800H Series With S, S8, L and L8 Drum
Low Profile Mount - Direct Drive

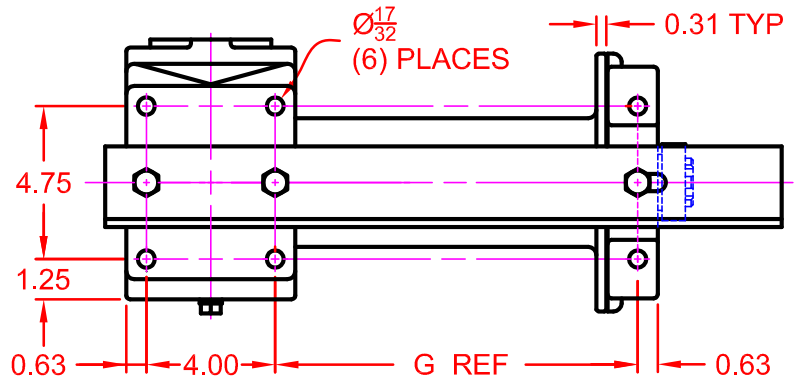
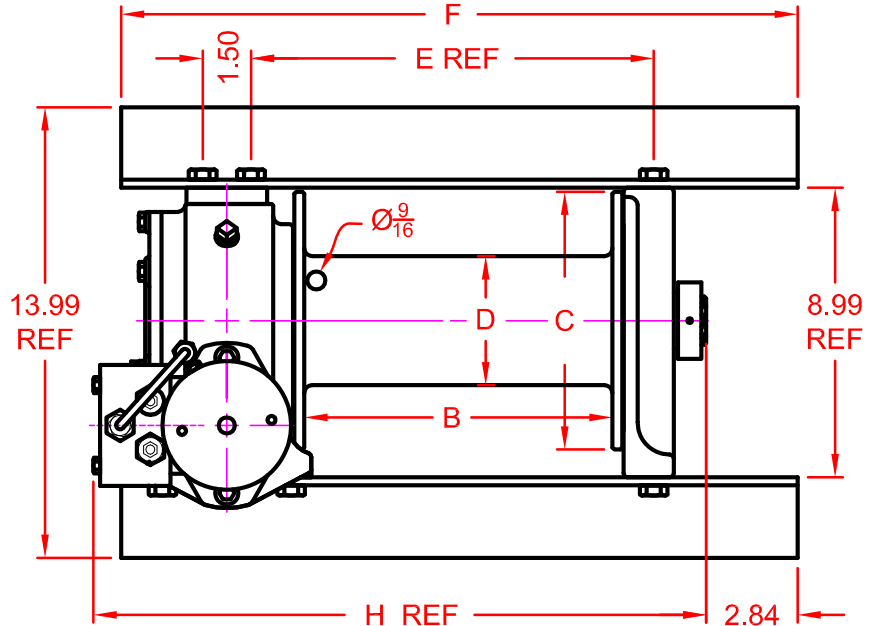
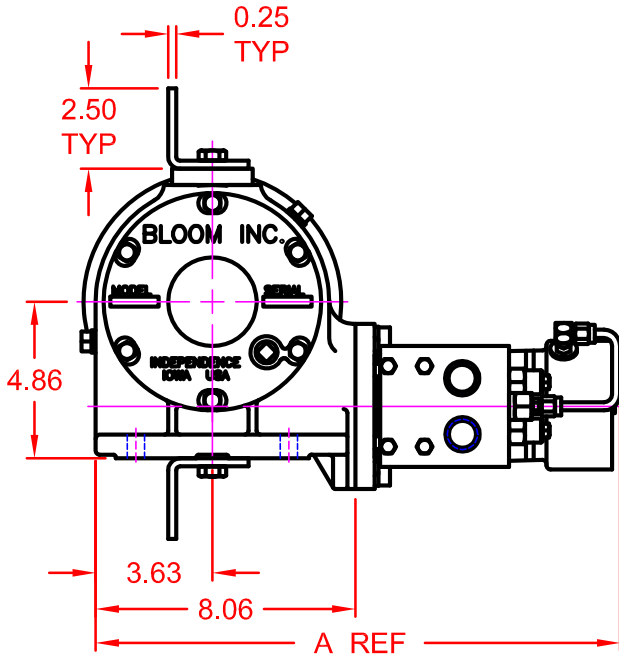

MOTOR DESIGNATION	3.0	6.2
A DIMENSION	15.91	16.28

DRUM DESIGNATION	WINCH DIMENSION						
	B	C	D	E	F	G	H
S	7.19	6	3.50	9.50	18.00	8.25	14.50
S8	7.19	8	4	9.50	18.00	8.25	14.50
L	10.19	6	3.50	12.50	21.00	11.25	17.50
L8	10.19	8	4	12.50	21.00	11.25	17.50

Bloom Manufacturing Inc.

Winch Division
1443 220th Street
Independence, IA 50644

www.bloommfg.com
Email: sales@bloommfg.com engineering@bloommfg.com

800-394-1139 tel
319-827-1139 tel
319-827-1140 fax



Correct choice of Directional Control Valves for Lift-Safe® Winches

All **Lift-Safe®** Winches require a **Motor Spool Control Valve**.

That is the valve's work ports are **open** to tank in neutral position.

*Winches require ridged mounting plate.
See owner's manual for information about proper mounting plate thickness or call Bloom Sales Engineer at factory

WARNING!

Goods are not intended for use in the moving or lifting of persons!

The winches described herein are neither designed nor intended for use or application to equipment used in the lifting or moving of persons and it is understood that all such use shall be at the sole risk of the user.

The cable clamps on winches are not designed to hold rated loads. A minimum of 5 wraps of cable must be left on drum barrel to guarantee holding of rated load.

Applications of winch where life would be endangered by any event are not recommended.



BLOOM Manufacturing Inc.
Winch Division

1443 220th Street,, Independence, Iowa 50644

FAX 319-827-1140 PHONE 319-827-1139